

**P-WC SERIES: 600 VOLT**

MODEL	W	H	L	TYPE	CAPACITY	AMPS
	in[mm]	in[mm]	in[mm]		ft[m]	
P-WC13-3506	8.5 [216]	14.5 [368]	13.75 [349]	6 GA	35 [11]	75
P-WC13-5006	8.5 [216]	14.5 [368]	13.75 [349]	6 GA	50 [15]	75
P-WC13-3504	8.5 [216]	14.5 [368]	13.75 [349]	4 GA	35 [11]	150
P-WC13-5004	8.5 [216]	14.5 [368]	13.75 [349]	4 GA	50 [15]	150
P-WC13-3502	8.5 [216]	14.5 [368]	13.75 [349]	2 GA	35 [11]	225
P-WC13-5002	11 [255]	17.25 [438]	17.25 [438]	2 GA	50 [15]	225
P-WC13-2501	8.5 [216]	14.5 [368]	13.75 [349]	1 GA	25 [7.6]	300
P-WC17-5001	11 [255]	17.25 [438]	17.25 [438]	1 GA	50 [15]	300
P-WC13-2510	8.5 [216]	14.5 [368]	13.75 [349]	1/0	25 [7.6]	350
P-WC17-5010	11 [255]	17.25 [438]	17.25 [438]	1/0	50 [15]	350
P-WC17-3520	11 [255]	17.25 [438]	17.25 [438]	2/0	35 [11]	450
P-WC17-5020	11 [255]	17.25 [438]	17.25 [438]	2/0	50 [15]	450

**CAUTION:** WHEN USING REEL FOR EXTENDED PERIODS OF TIME- UNWIND ALL CABLE TO PREVENT HEAT BUILD-UP

**100WCL SERIES**

MODEL	W	H	L	1/4" CAPACITY	WEIGHT
	in[mm]	in[mm]	in[mm]	ft[m]	lb[kg]
112W-1-50	15.25 [387]	13 [463]	12 [305]	50 [15]	18 [8]
112W-1-100	18.75 [476]	13 [463]	12 [305]	100 [30]	18 [8]
117W-1-200	18.25 [463]	18 [457]	17 [431]	200 [60]	30 [14]

**CAUTION:** WHEN USING REEL FOR EXTENDED PERIODS OF TIME- UNWIND ALL CABLE TO PREVENT HEAT BUILD-UP

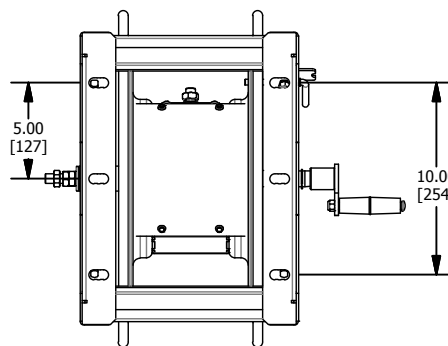
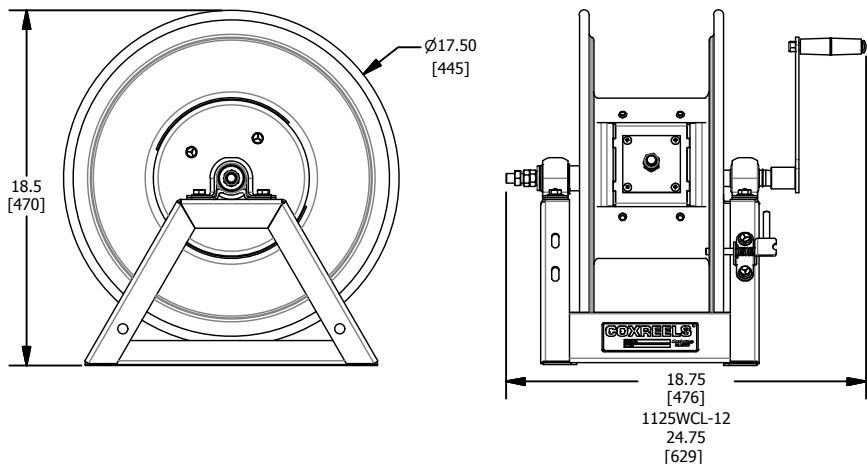
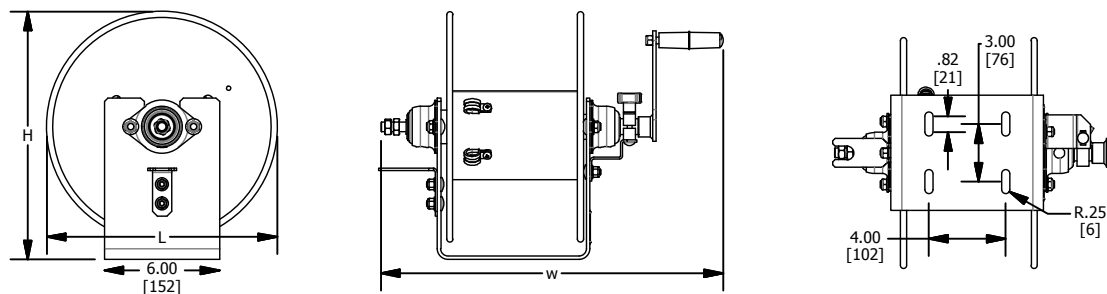

MATERIAL SPECIFICATIONS		
COMPONENT	MATERIAL	OPTIONS
SLIP RING	450 AMP	-
REEL	STEEL	-
BEARINGS	BRONZE, SELF LUBE 100 ONLY- COMPOSITE	-
BALL STOP	RUBBER	STAINLESS HARDWARE
LOCKING PAWL	BRASS (NON-SPARKING)	-
FINISH	BLUE POWDER COAT (B)	RED(R), GREEN(N), WHITE(W), BLACK [WRINKLE(C)/GLOSS(K)], GREY(G) 100 ONLY-STAINLESS

MODEL	#2 CABLE	#1 CABLE	#1/0 CABLE	#2/0 CABLE	WEIGHT
	ft [m]	ft [m]	ft [m]	ft[m]	lb[kg]
1125WCL-6-X	300 [91]	250 [76]	200 [61]	150 [45]	38 [17]
1125WCL-12-X	600 [183]	500 [152]	400 [122]	300 [91]	45 [20]

X= MOTOR OPTIONS

\*MOTOR AND CRANK DIMENSIONALLY SAME AS 1125 SERIES

**UNLISTED OPTIONS & CUSTOM REELS**

NOT ALL OPTIONS ARE LISTED, CONTACT YOUR SALES REPRESENTATIVE OR FACTORY FOR ADDITIONAL OPTIONS & CUSTOM MODIFICATIONS

**COXREELS**

5865 S Ash Avenue Tempe, Az 85283  
1-800-COX-REEL www.coxreels.com

THIS DOCUMENT CONTAINS PROPRIETARY INFORMATION AND IS THE PROPERTY OF COXREELS, INC. THE COPYING, DISTRIBUTION AND UTILIZATION OF THIS DOCUMENT AS WELL AS COMMUNICATION OF ITS CONTENT TO OTHERS WITHOUT THE WRITTEN AUTHORIZATION OF COXREELS, INC., IS PROHIBITED.

TITLE:

**WELD CABLE REELS**

DWG. NO.:

**XXXWCL SERIES**

REV. -

3RD ANGLE



INTERPERT PER ASME : Y14.5M-1994  
DO NOT SCALE DWG.

SIZE: A  
SHT: 1 OF: 1